



Technical Specification | Mini Pumps

Mini Lime

Part No: Various



ASPEN-5/09

Dimensions:

Height: 79mm
 Width: 99mm
 Depth: 44mm
 Weight: 0.31kg

Power Supply:

- 230V AC, 15W
- 1PH 50 Hz
- 3A volt-free alarm wires, N.O., N.C. contacts rated @ 5A inductive at 230V

In The Box:

- Mini Lime pump
- Breather tube
- Green discharge tube with connector
- Internal conduit sleeve
- Conduit front and back
- Elbow kit
- Trunking
- Ceiling plate
- Inlet hose, rawl plugs and screws
- Cable ties

Other Features:

- Hall effect semi conductor level sensors, with high level safety
- Fully potted
- Thermally protected
- CE marked

Performance:

- Water flow rate: 11ltrs/hour at zero head
- Maximum recommended head: 10 metres
- 23dB(A) @ 1 metre

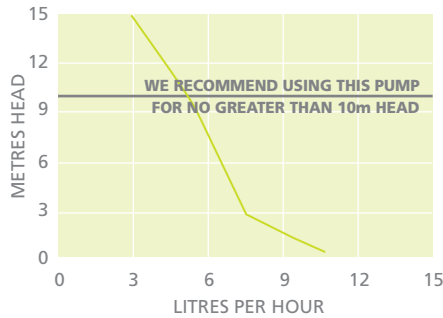

VERTICAL PUMPING HEAD	HORIZONTAL			
	30m	60m	90m	100m Max
3m	7.6	7.6	7.6	Ltr/Hr
2m	8.3	8.3	8.3	Ltr/Hr
1m	8.5	8.5	8.5	Ltr/Hr

Systems Available:

Slimline	Ivory	FP1500
	White	FP2857
BBJ	Ivory	FP2083
	White	FP2856
Inoac	Ivory	FP2100
	White	FP2855
Optimal	White	FP2291
Artiplastic	Ivory	FP2077
OEM		FP2124

Installation:

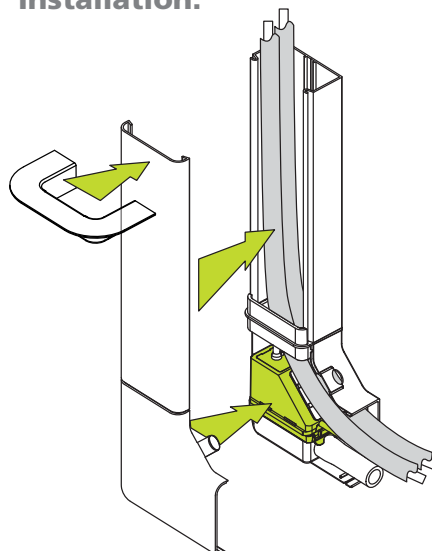

The Aspen Mini Lime pump is completely unique, in both design and installation advantages. The pump is clipped directly onto the reservoir so there is minimal suction lift. By connecting the drain hose to the reservoir of the pump unit, condensate water can be pumped away to a suitable drain.

The pump fits securely into a specifically designed elbow that holds it horizontally to ensure reliable operation. The pump and elbow are reversible therefore it can be installed easily on either side of an evaporator unit. The Lime system makes installation easy by providing a pump complete with the conduit trunking, in which the pump and all pipework are hidden. This system allows easy access for maintenance and ensures that the reservoir is level at all times.

- **Completely reversible**
- **Quick and easy to install**



Apex Way Hailsham
 East Sussex BN27 3WA
 T: +44 (0)1323 848842
 F: +44 (0)1323 848846
 sales@aspenspumps.com
www.aspenpumps.com